

the test bakery
before PABLO & PISTACHIO
OFFICE DESIGN LAYOUT

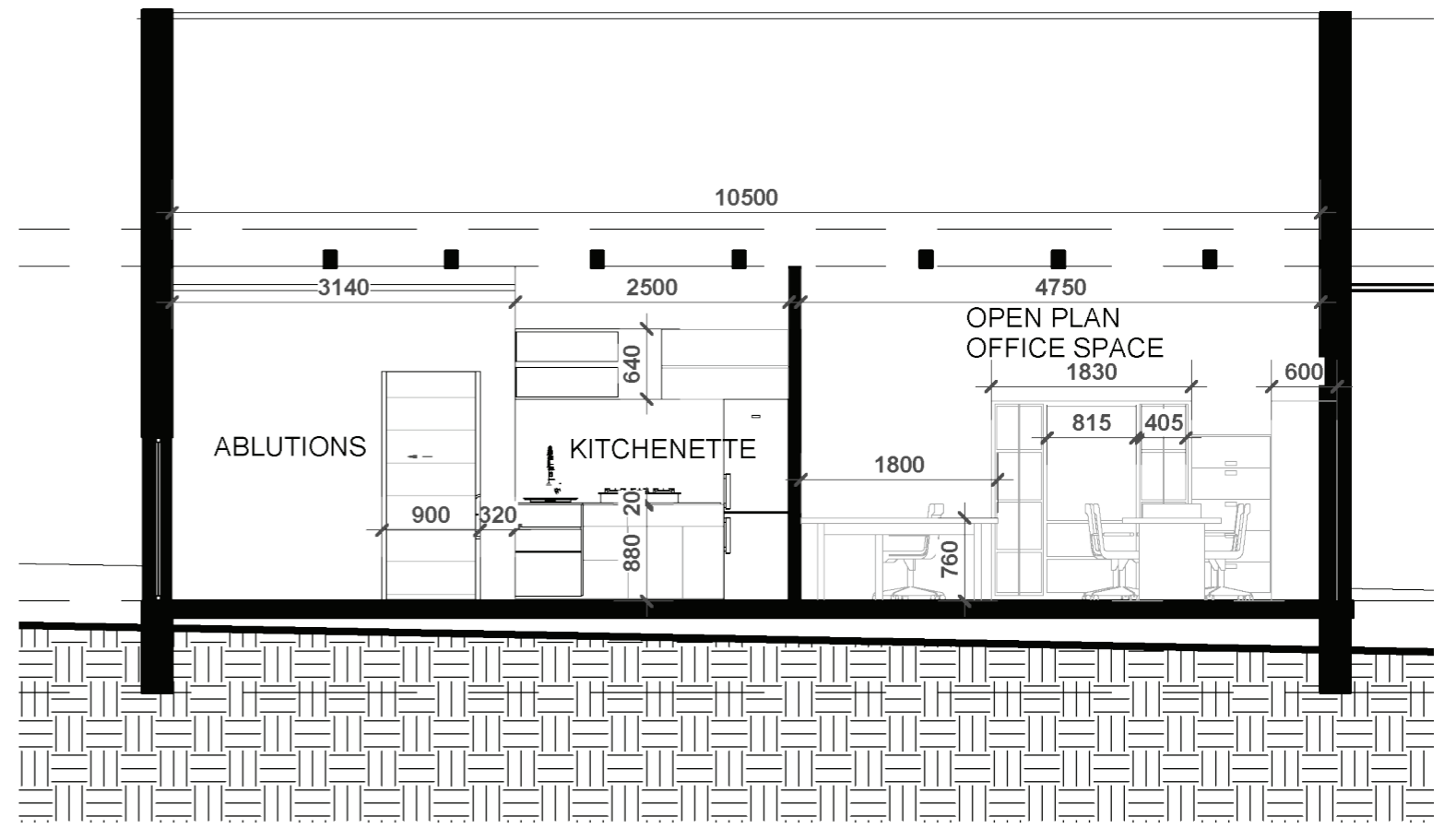

DESIGNED BY MUJAAHID BULBULIA | MBRACE SPACE

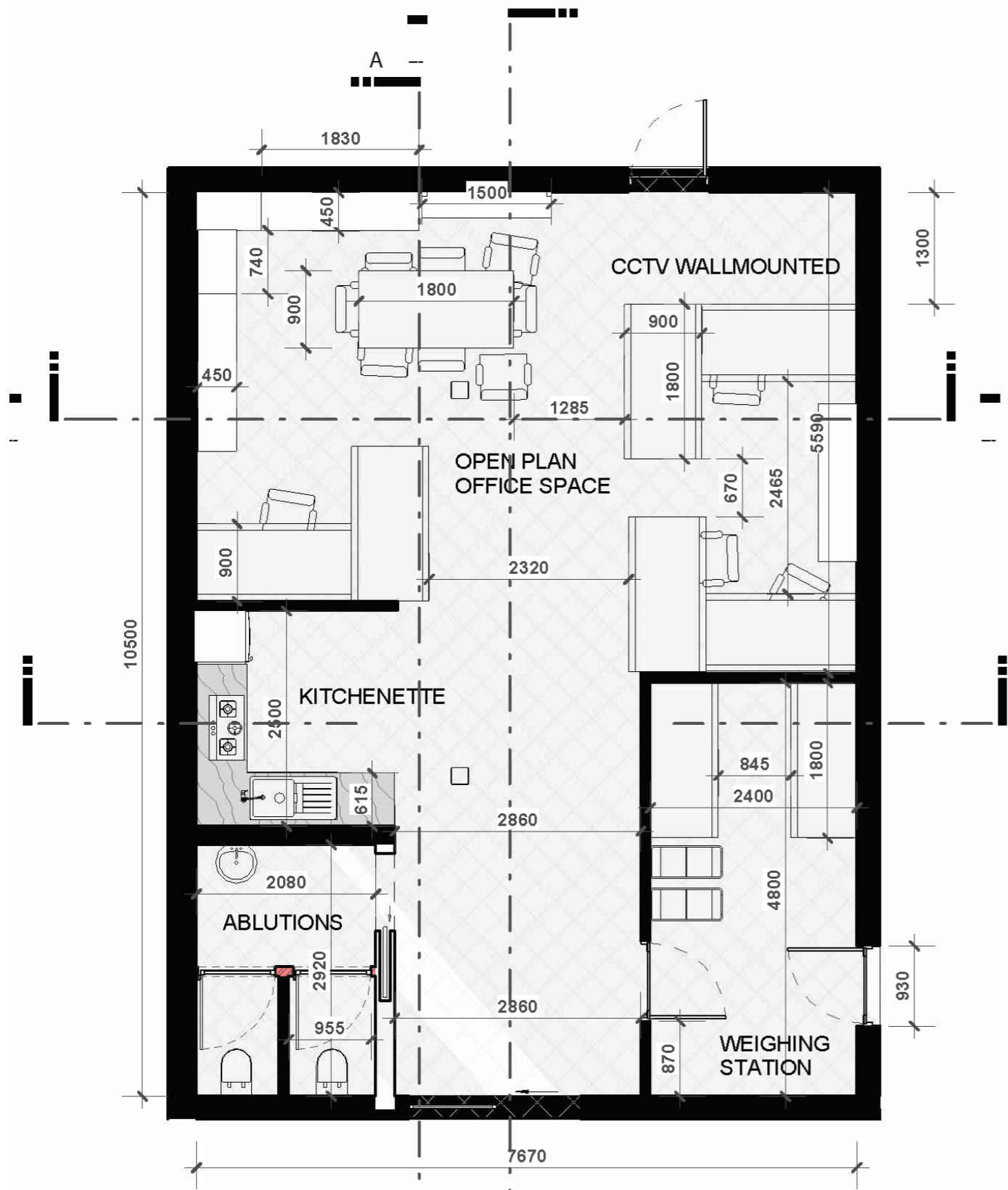

NEW PROPOSED OFFICE SECTION A-A



THE REDESIGN OF THE TEST BAKERY OFFICE SPACE OPTIMIZES WORKFLOW BY MERGING COLLABORATIVE AREAS WITH TECHNICAL PRECISION.

A CENTRAL OPEN-PLAN LAYOUT COMFORTABLY ACCOMMODATES FIVE STAFF MEMBERS, WHILE A NEW DEDICATED WEIGHING AREA SUPPORTS SPECIALIZED OPERATIONAL TASKS. THE KITCHENETTE IS STRATEGICALLY POSITIONED AS A DISCRETE UTILITY, PROVIDING ESSENTIAL SUPPORT WITHOUT ENCROACHING ON THE PRIMARY WORKSPACE. THIS ZONING ENSURES A PROFESSIONAL, CLUTTER-FREE ATMOSPHERE THAT REFLECTS THE BRAND'S COMMITMENT TO BOTH CRAFT AND EFFICIENCY.

the test bakery
before PABLO & PISTACHIO

NEW PROPOSED OFFICE FLOOR PLAN LAYOUT



■ KITCHENETTE SPACE

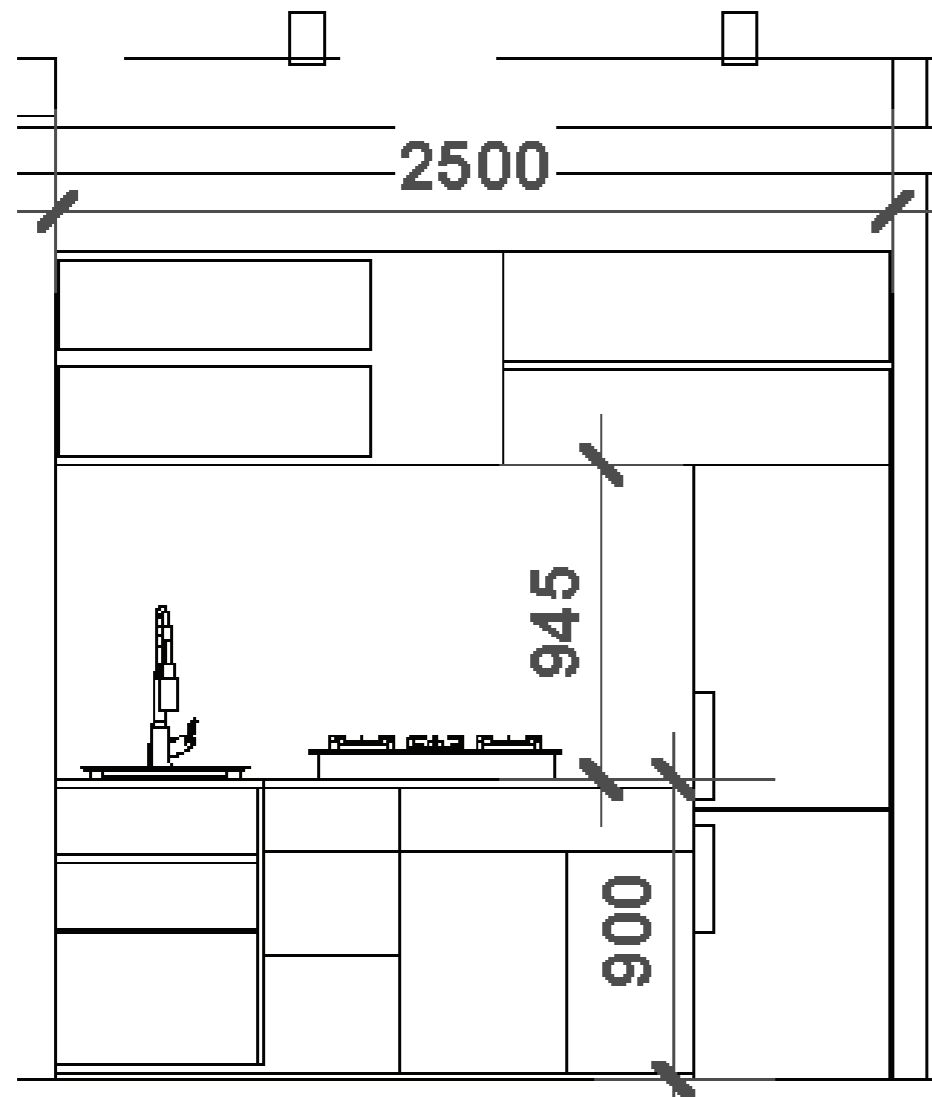

NEW PROPOSED OFFICE KITCHENETTE ELEVATION

THE KITCHENETTE CONSISTS OF A SINGLE SINK, A TWO-PLATE STOVE, CUPBOARD STORAGE, AND A COMBINED FRIDGE AND FREEZER. IT FITS WITHIN A 2500MM-WIDE SPACE AND IS DESIGNED AS A SEMI-SEPARATED AREA, ALLOWING KITCHEN ACTIVITIES TO REMAIN DISTINCT FROM THE MAIN LIVING SPACE WHILE STILL MAINTAINING A SENSE OF OPENNESS RATHER THAN COMPLETE SEGREGATION.



KITCHENETTE SECTION OF THE OFFICE

the test bakery
before PABLO & PISTACHIO



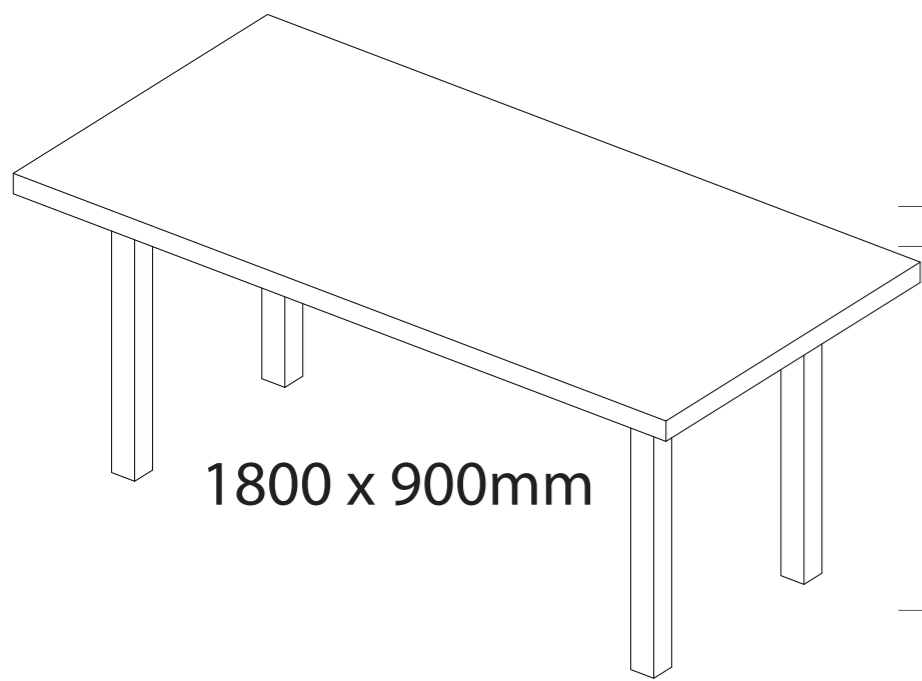

1800 x 900mm

EXISTING USABLE FURNITURE

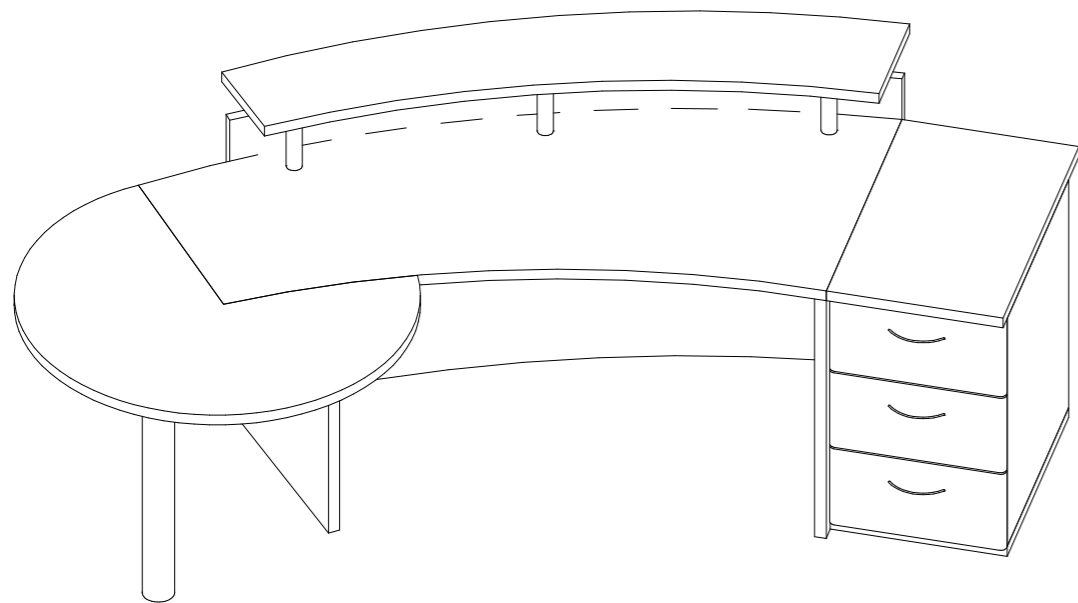

DRAFTED POSSIBLE FURNITURE DESIGN

THE TEST BAKERY OFFICE IS A MINIMALIST, HIGH-FUNCTIONING WORKSPACE DESIGNED FOR COLLABORATIVE EFFICIENCY. THE OPEN-PLAN LAYOUT COMFORTABLY ACCOMMODATES FIVE STAFF MEMBERS WHILE INTEGRATING A DEDICATED WEIGHING AREA FOR TECHNICAL PRECISION. SPATIAL ZONING KEEPS THE KITCHENETTE DISCRETE, ENSURING UTILITY WITHOUT DISRUPTING THE PROFESSIONAL FLOW. THIS STREAMLINED ENVIRONMENT PRIORITIZES OPERATIONAL CLARITY AND BRAND COHESION.

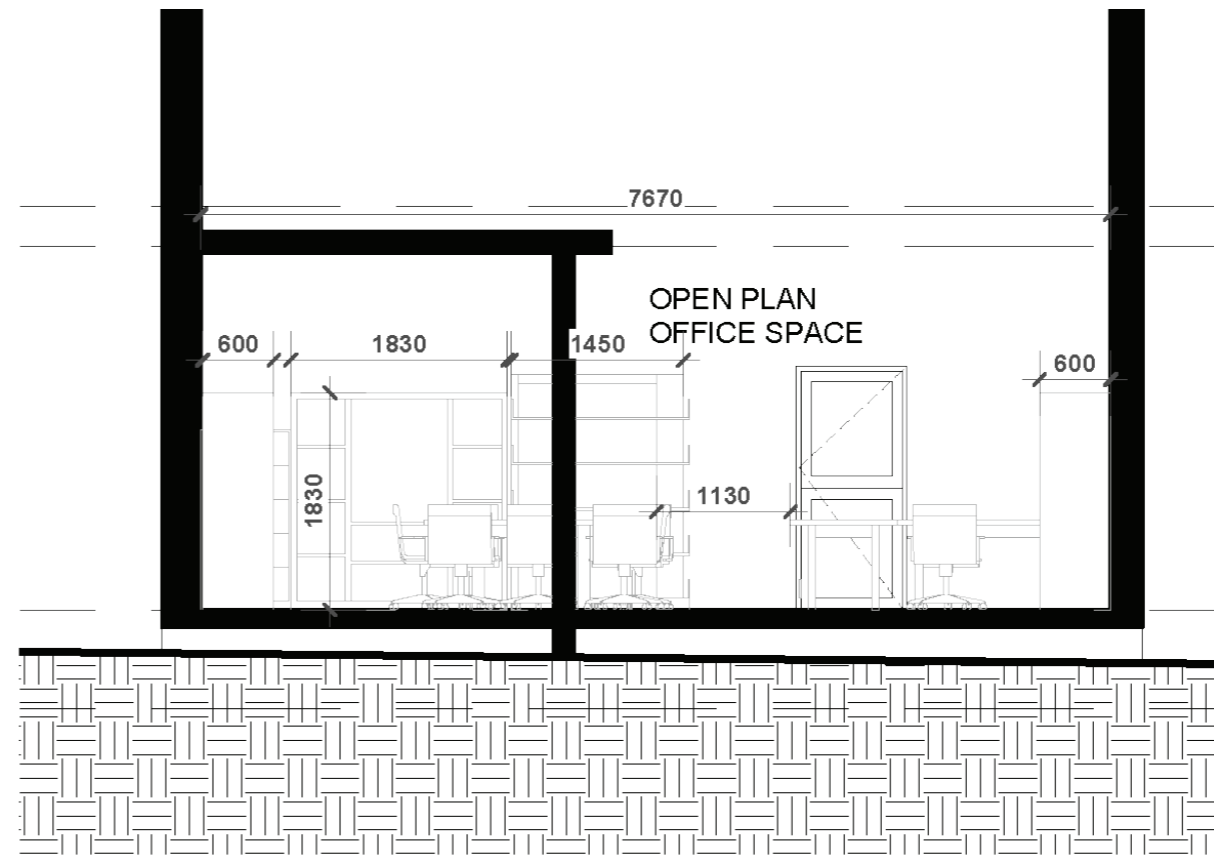

NEW PROPOSED OFFICE SECTION B-B

3400 Underside
3060 Lintel
UFF
Height

0 Ground
UFF
Floor
-835 Foundation
UFF
Level



HEAD OF OFFICE SEATING ARRANGEMENTS

WEIGHING SPACE

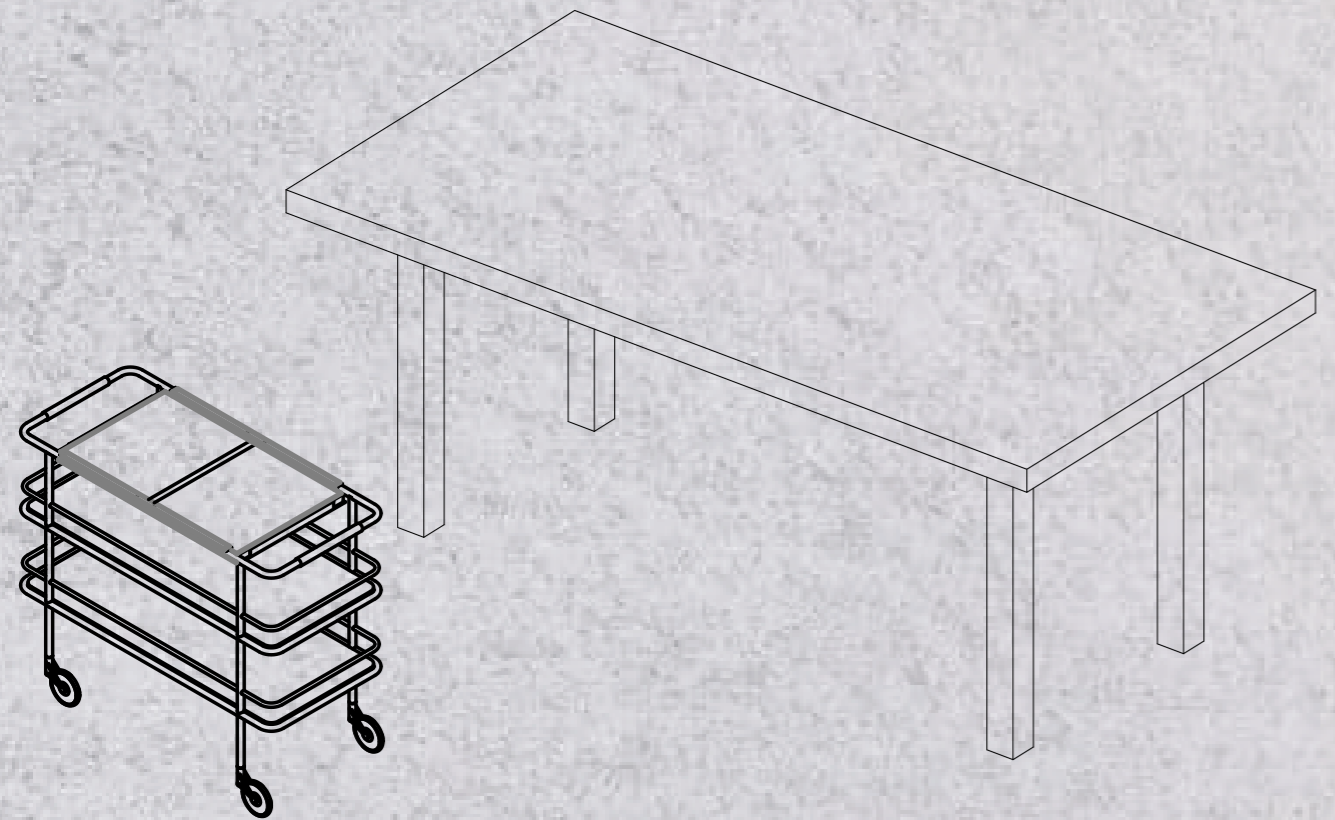

WEIGHING AND CUTTING TABLES
WITH ADJUSTABLE DESIGNS
1700MM X 600MM

the test bakery
before PABLO & PISTACHIO

